



DATACENTRE



E-MEDICAL



INDUSTRY



TRANSPORT



EMERGENCY

Master MPS



ONLINE



Tower



3:1 10-120 kVA

3:3 10-200 kVA



SmartGrid ready



Flywheel compatible



Supercaps UPS



Service 1st start



HIGHLIGHTS

- Efficiency Control System (ECS)
- Robust and reliable
- Galvanic isolation
- High overload capacity
- Extensive parallel configurations

Total protection

Master MPS series UPS provide maximum protection and power quality for mission critical loads, including data centres, industrial processes, telecommunications, security and electro-medical systems. Master MPS is an on-line double conversion UPS (VFI SS 111 - IEC EN 62040-3) with a transformer isolated inverter.

The Master MPS range includes three-phase input and single-phase output versions from 10 to 120 kVA, and three-phase input and

output versions from 10 to 200 kVA.

All versions are provided with a 6-pulse thyristor-based rectifier, with or without optional harmonic filters.

A 12-pulse thyristor-based rectifier is available on request for the 60 and 80 kVA versions with or without optional harmonic filters.

Easy source

Master MPS makes supplying the UPS from generator sets and MT/BT transformers

simpler and more efficient, reducing power loss in the system and coils, correcting the power factor and eliminating current harmonics created by the loads supplied by the UPS.

In addition to this, the progressive rectifier start-up (power walk-in) and the option to reduce battery charging currents, allow for a reduction in the input current uptake. This means less demand on the source, which is particularly useful when the source is a generator set.

Flexibility

Master MPS is suitable for a wide range of applications including IT and the most demanding industrial environments. The UPS is suitable for power capacitive loads such as blade servers, from 0.9 leading to 0.8 lagging. With a broad range of accessories and options, complex configurations and system architectures can be achieved to guarantee maximum power availability and the option to add new UPS without interruption to existing installation.

Battery care system: maximum battery care

Normally the batteries are kept charged by the rectifier; when mains power fails, the UPS uses this energy source to power the consumers. Proper battery care is therefore critical to ensuring correct UPS operation under emergency conditions. The Riello UPS battery care system consists of a series of functions designed to optimise battery management and achieve the best performance and operating life possible. Master MPS is also compatible with different battery technologies: vented open lead acid, VRLA AGM, Gel, NiCd, Flywheels, Supercaps and Lithium.

Specific solutions

The UPS can be adapted to meet the most specific requirements. Contact our TEC team to discuss specific solutions and options not listed in this catalogue.

Advanced communications

- Compatible with TeleNetGuard for remote monitoring.
- Advanced multi-platform communications for all operating systems and network environments: PowerShield³ monitoring and shutdown software included for Windows operating systems 10, 8, 7, Hyper-V, 2016, 2012, and previous versions, Mac OS X, Linux, VMWare ESXi, Citrix XenServer and other Unix operating systems.
- Double RS232 serial

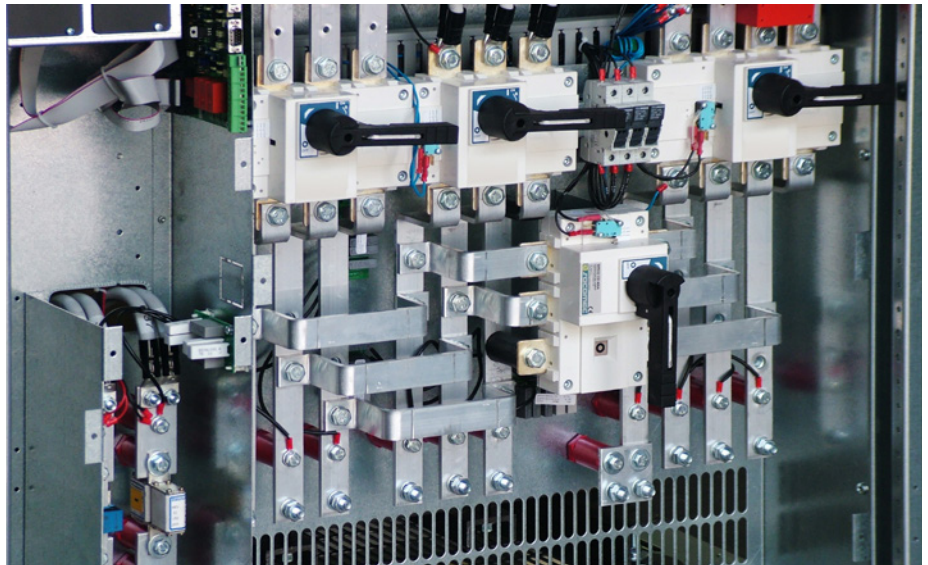

Detail of connection area

- 2 slots for the installation of optional communications accessories such as network adapters, potential free contacts, etc.
- REPO Remote Emergency Power Off for switching off the UPS via a remote emergency button
- Input for the connection of the auxiliary contact of an external manual bypass
- Input for synchronisation from an external source
- Graphic display panel for remote connection.

Maximum reliability and availability

- Distributed or centralised parallel configuration of up to 8 units per redundant (N+1) or power parallel system. Parallel configurations using models with different power ratings are also possible.
- Hot System Expansion (HSE): allows the addition of a further UPS into an existing system, without the need to switch off the existing UPS or transfer them to bypass mode. This guarantees maximum load protection, even during maintenance and system expansion.
- Maximum levels of availability, even in the event of an interruption to the parallel bus cable: the system is "FAULT TOLERANT". It is not affected by connection cable faults and continues powering the load without disruption, signalling an alarm condition.
- Efficiency Control System (ECS): a system to optimise the operating efficiency of parallel systems, according to the power required by the load. N+1 redundancy is guaranteed, with every UPS working in parallel at the best load level possible to achieve higher overall efficiency.

Options

• UPS Group Synchroniser (UGS)

Allows two or more non-parallel UPS devices to remain synchronised even during mains power failure. The UGS also enables a Riello UPS to be synchronised with another power source that is independent and of a different power rating.

• Parallel Systems Joiner (PSJ)

Allows two groups of UPS to be connected in parallel whilst operating, in the event of maintenance (with no interruption to the output), using a power coupling switch. Should one of the UPS in one of the parallel groups fail, it is automatically excluded. The PSJ connects the remaining UPS, to the other parallel group via an external bypass, in order to continue to guarantee load redundancy.

DIMENSIONS

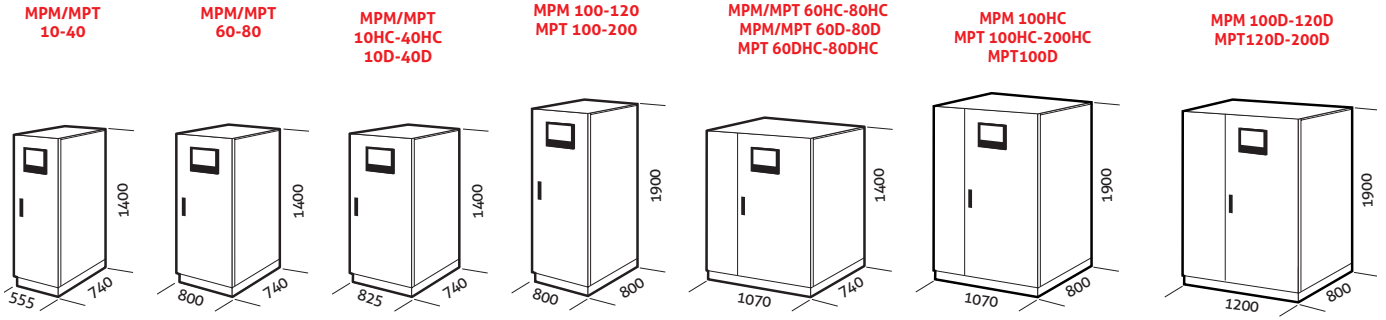

HC= Version with filtering of 5th or 11th harmonics D= Twelve-phase version

DYNAMIC DUAL BUS CONFIGURATION

Solution to ensure redundancy up to the distribution of the power supply to the loads and improved STS operation.
+ Downstream fault discrimination

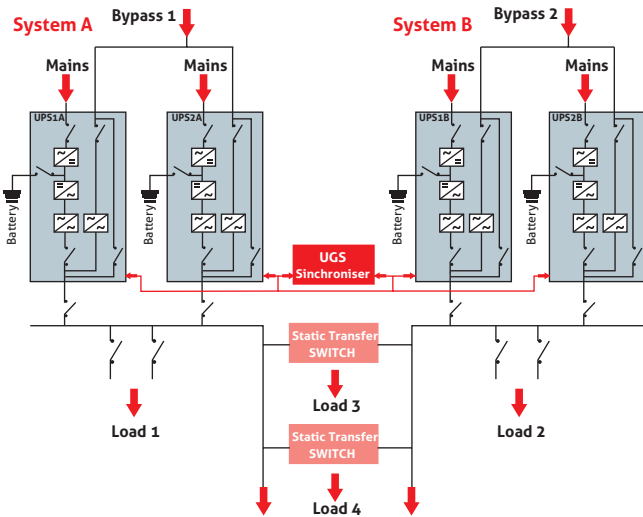

DUAL BUS SYSTEM CONFIGURATION

Solution to ensure redundancy of the power supply even during maintenance. **+ High availability and redundancy**

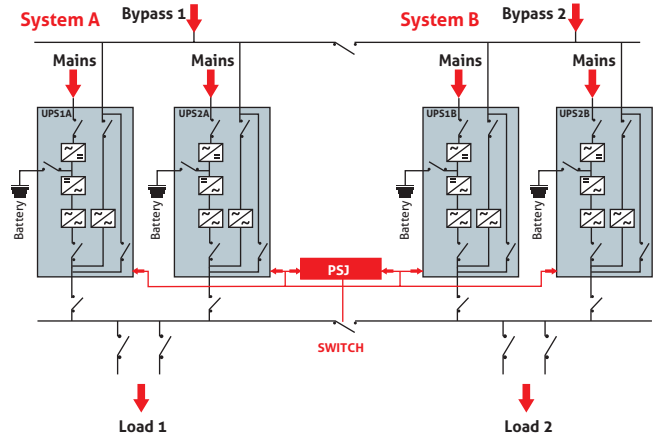

DETAILS



MPT 200 open

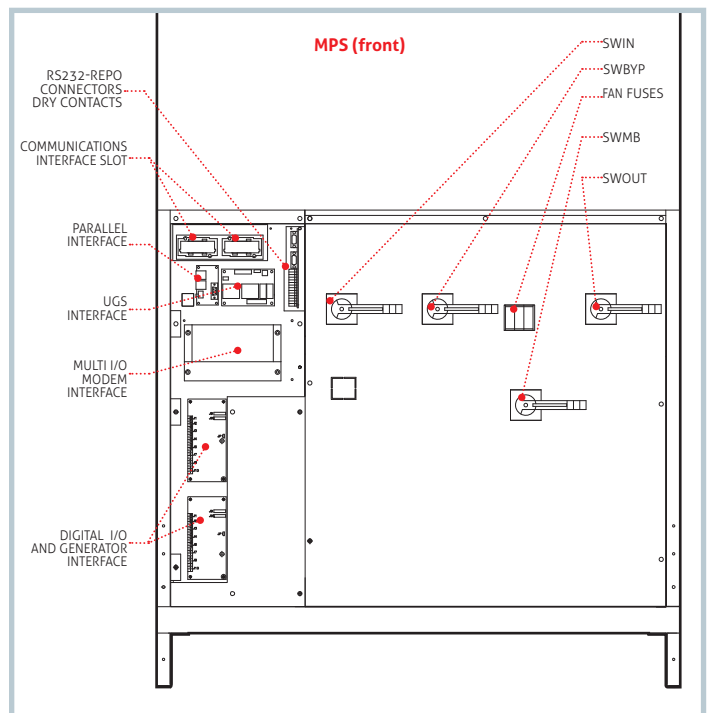

OPTIONS

SOFTWARE

PowerShield³
PowerNetGuard

ACCESSORIES

NETMAN 204
MULTICOM 302
MULTICOM 352
MULTI I/O

MULTIPANEL
MBB 100 A

PRODUCT ACCESSORIES

Filtering of 5th and 11th harmonics (HC)
Isolation transformer
Synchronisation device (UGS)
Hot connection device (PSJ)
Digital I/O and Generator interface

Parallel configuration kit (Closed Loop)
Battery cabinets empty or for extended runtimes
Top Cable Entry cabinets
IP rating IP31/IP42

BATTERY BOX

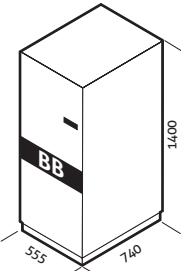
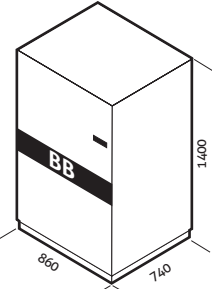
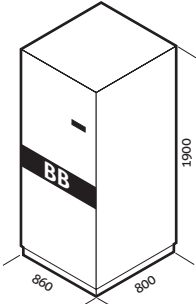
MODELS	BB 1400 384-B1	BB 1400 384-B2 / BB 1400 384-B3 BB 1400 384-B4	BB 1900 396-L6 / BB 1900 396-L7 BB 1900 396-L8 / BB 1900 396-L9
UPS MODELS	MPT 10-60 / MPM 10-60	MPT 10-80 / MPM 10-80	MPT 100-200 / MPM 100-120
Dimensions (mm)			

CABINETS WITH TOP ACCESS FOR CABLES

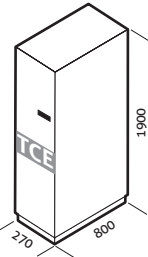
MODELS	TCE MPT 100-200
UPS MODELS	MPT 100-200 / MPM 100-120
Dimensions (mm)	

SINGLE-PHASE ISOLATION TRANSFORMERS

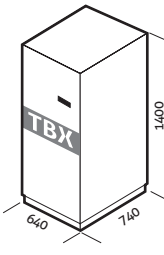
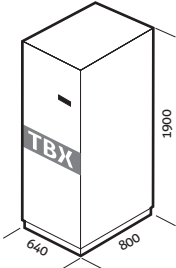
MODELS	TBX 10 M - TBX 80 M	TBX 100 M
UPS MODELS	MPT 10-80	MPT 100-120
Dimensions (mm)		

THREE-PHASE ISOLATION TRANSFORMERS

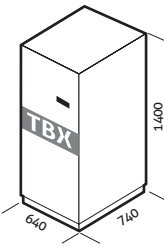
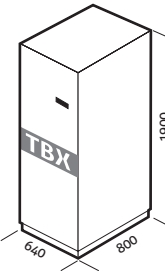
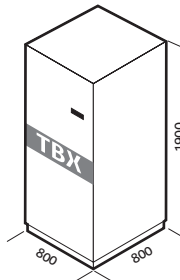
MODELS	TBX 10 T - TBX 80 T	TBX 100 T - TBX 160 T	TBX 200 T - TBX 250 T
UPS MODELS	MPT 10-80	MPT 100-160	MPT 200
Dimensions (mm)			

MODELS	MPM 10 ^{BAT}	MPM 15 ^{BAT}	MPM 20 ^{BAT}	MPM 30	MPM 40	MPM 60	MPM 80	MPM 100	MPM 120	
INPUT										
Nominal voltage	380 - 400 - 415 Vac three-phase									
Voltage tolerance	400 V + 20% /- 25%									
Frequency	45 - 65 Hz									
Soft start	0 - 100% in 120" (selectable)									
Permitted frequency tolerance	± 2% (selectable from ± 1% to ± 5% from front panel)									
Standard equipment provided	Back Feed protection; separable bypass line									
BYPASS										
Nominal voltage	220 - 230 - 240 Vac single-phase + N									
Nominal frequency	50 or 60 Hz (selectable)									
OUTPUT										
Nominal power (kVA)	10	15	20	30	40	60	80	100	120	
Active power (kW)	9	13.5	18	27	36	54	72	90	108	
Number of phases	1									
Nominal voltage	220 - 230 - 240 Vac single-phase + N (selectable)									
Static stability	± 1%									
Dynamic stability	± 5% in 10 ms									
Voltage distortion	< 1% with linear load / < 3% with non-linear load									
Crest factor	3:1 Ipeak/Irms									
Frequency stability on battery	0.05%									
Frequency	50 or 60 Hz (selectable)									
Overload	110% for 60 minutes; 125% for 10 minutes; 150% for 1 minute									
BATTERIES										
Type	VRLA AGM / GEL; NiCd; Supercaps; Li-ion; Flywheels									
Residual ripple voltage	< 1%									
Temperature compensation	-0.5 Vx°C									
Typical charge current	0.2 x C10									
INFO FOR INSTALLATION										
Weight without batteries (kg)	200	220	230	270	302	440	500	580	1000	
Dimensions (WxDxH) (mm)	555 x 740 x 1400					800 x 740 x 1400		800 x 800 x 1900	1200 x 800 x 1900	
Remote signals	dry contacts									
Remote controls	ESD and bypass									
Communications	Double RS232 + dry contacts + 2 slots for communications interface									
Operating temperature	0 °C/ +40 °C									
Relative humidity	<95% non-condensing									
Colour	Dark grey RAL 7016									
Noise level at 1 m (ECO Mode)	60 dBA			62 dBA						
IP rating	IP20									
Smart Active efficiency	up to 98%									
Standards	Directives LV 2014/35/EU - 2014/30/EU; Safety IEC EN 62040-1; EMC IEC EN 62040-2; Performance IEC EN 62040-3									
Classification in accordance with IEC 62040-3	(Voltage Frequency Independent) VFI - SS - 111									
Moving the UPS	Pallet Jack									

^{BAT} Also available with internal batteries

MODELS	MPT 10 ^{BAT}	MPT 15 ^{BAT}	MPT 20 ^{BAT}	MPT 30	MPT 40	MPT 60	MPT 80
INPUT							
Nominal voltage	380 - 400 - 415 Vac three-phase						
Voltage tolerance	400 V + 20% / - 25%						
Frequency	45 - 65 Hz						
Soft start	0 - 100% in 120" (selectable)						
Permitted frequency tolerance	± 2% (selectable from ± 1% to ± 5% from front panel)						
Standard equipment provided	Back Feed protection; separable bypass line						
BYPASS							
Nominal voltage	380 - 400 - 415 Vac three-phase + N						
Nominal frequency	50 or 60 Hz (selectable)						
OUTPUT							
Nominal power (kVA)	10	15	20	30	40	60	80
Active power (kW)	9	13.5	18	27	36	54	72
Number of phases	3 + N						
Nominal voltage	380 - 400 - 415 Vac three-phase + N (selectable)						
Static stability	± 1%						
Dynamic stability	± 5% in 10 ms						
Voltage distortion	< 1% with linear load / < 3% with non-linear load						
Crest factor	3:1 I _{peak} /I _{rms}						
Frequency stability on battery	0.05%						
Frequency	50 or 60 Hz (selectable)						
Overload	110% for 60 minutes; 125% for 10 minutes; 150% for 1 minute						
BATTERIES							
Type	VRLA AGM / GEL; NiCd; Supercaps; Li-ion; Flywheels						
Residual ripple voltage	< 1%						
Temperature compensation	-0.5 V/°C						
Typical charge current	0.2 x C10						
INFO FOR INSTALLATION							
Weight without batteries (kg)	228	241	256	315	335	460	540
Dimensions (WxDxH) (mm)	555 x 740 x 1400					800 x 740 x 1400	
Remote signals	dry contacts						
Remote controls	ESD and bypass						
Communications	Double RS232 + dry contacts + 2 slots for communications interface						
Operating temperature	0 °C / +40 °C						
Relative humidity	<95% non-condensing						
Colour	Dark grey RAL 7016						
Noise level at 1 m (ECO Mode)	60 dBA				62 dBA		
IP rating	IP20						
Smart Active efficiency	up to 98%						
Standards	Directives LV 2014/35/EU - 2014/30/EU; Safety IEC EN 62040-1; EMC IEC EN 62040-2; Performance IEC EN 62040-3						
Classification in accordance with IEC 62040-3	(Voltage Frequency Independent) VFI - SS - 111						
Moving the UPS	Pallet Jack						

^{BAT} Also available with internal batteries

MODELS	MPT 100	MPT 120	MPT 160	MPT 200
INPUT				
Nominal voltage	380 - 400 - 415 Vac three-phase			
Voltage tolerance	400 V + 20% /- 25%			
Frequency	45 - 65 Hz			
Soft start	0 - 100% in 120" (selectable)			
Permitted frequency tolerance	± 2% (selectable from ± 1% to ± 5% from front panel)			
Standard equipment provided	Back Feed protection; separable bypass line			
BYPASS				
Nominal voltage	380 - 400 - 415 Vac three-phase + N			
Nominal frequency	50 or 60 Hz (selectable)			
OUTPUT				
Nominal power (kVA)	100	120	160	200
Active power (kW)	90	108	144	180
Number of phases	3 + N			
Nominal voltage	380 - 400 - 415 Vac three-phase + N (selectable)			
Static stability	± 1%			
Dynamic stability	± 5% in 10 ms			
Voltage distortion	< 1% with linear load / < 3% with non-linear load			
Crest factor	3:1 lpeak/lrms			
Frequency stability on battery	0.05%			
Frequency	50 or 60 Hz (selectable)			
Overload	110% for 60 minutes; 125% for 10 minutes; 150% for 1 minute			
BATTERIES				
Type	VRLA AGM / GEL; NiCd; Supercaps; Li-ion; Flywheels			
Residual ripple voltage	< 1%			
Temperature compensation	-0.5 V/°C			
Typical charge current	0.2 x C10			
INFO FOR INSTALLATION				
Weight (kg)	600	610	690	790
Dimensions (WxDxH) (mm)	800 x 800 x 1900			
Remote signals	dry contacts			
Remote controls	ESD and bypass			
Communications	Double RS232 + dry contacts + 2 slots for communications interface			
Operating temperature	0 °C / +40 °C			
Relative humidity	<95% non-condensing			
Colour	Dark grey RAL 7016			
Noise level at 1 m (ECO Mode)	65 dBA	68 dBA		
IP rating	IP20			
Smart Active efficiency	up to 98%			
Standards	Directives LV 2014/35/EU - 2014/30/EU; Safety IEC EN 62040-1; EMC IEC EN 62040-2; Performance IEC EN 62040-3			
Classification in accordance with IEC 62040-3	(Voltage Frequency Independent) VFI - SS - 111			
Moving the UPS	Pallet Jack			

For ranges above 200 KVA please consult our Technical Department.

RPS S.p.A.

ITALY

LEGNAGO (VR)

Head Office

Viale Europa, 7
37045 LEGNAGO (Verona)
Tel +39 0442 635811
www.riello-ups.com
riello@riello-ups.com

CORMANO (MI)

Sales Office

Via Somalia, 20
20032 CORMANO (Milano)
Tel +39 02 663271



PRE-SALES SUPPORT

(TEC)

tec@riello-ups.com



AFTER-SALES SUPPORT

(UPService)

service@riello-ups.com

Worldwide Subsidiary Companies

USA

RPS America, Inc.

8808 Beckett Rd
West Chester, OH 45069
Tel +1-513-282-3777

UNITED KINGDOM

RIELLO UPS Ltd.

Unit 50 Clywedog Road North
Wrexham Industrial Estate
Wrexham LL13 9XN
Tel +44 800 269 394

CONSTANT POWER SERVICES Ltd.

Riello House, Works Road,
Letchworth
SG6 1AZ Hertfordshire
Tel +44 330 1230125

GERMANY

RIELLO UPS GmbH

Wilhelm-Bergner-Str. 9b
21509 Glinde
Tel +49 40 / 527 211-0

RIELLO POWER SYSTEMS GmbH

Neufahrner Str. 12b
85375 Neufahrn/Grüneck
Tel +49 8165 / 9458-0

FRANCE

RIELLO ONDULEURS S.a.r.l.

4 Rue du Bois Chaland,
ZAC du Bois Chaland
91090 Lisses
Tel +33 1 60 875454

SPAIN

RIELLO ENERDATA s.l.u.

C/ Labradores,
13 Parque Empresarial
Prado del Espino
28660 Boadilla del Monte
Madrid
Tel +34 916 333 000

RIELLO TDL s.l.

C/Berguedà, 6 bis
Pol. Ind. Plà de la Bruguera
08211 Castellar del Vallès, Barcelona
Tel +34 902 02 66 54

ROMANIA

RIELLO UPS ROMANIA S.r.l.

Str. Varsovia Nr. 4
307160 Dumbravita
Timis County - Romania
Tel +40 256 214 681

POLAND

RIELLO DELTA POWER Sp. z o.o.

ul. Krasnowolska 82 R
02-849 Warszawa
Tel +48 22 379 17 00

AUSTRALIA

RIELLO UPS AUSTRALIA Pty. Ltd.

Unit 22/80 Box Road
Taren Point NSW 2229
Tel +61 2 9531 1999

ASIA PACIFIC

RIELLO UPS SINGAPORE Pte Ltd.

No. 506 Chai Chee Lane,
#07-01, Singapore 469026
Tel +65 6441 2005

CHINA

Riello UPS (Asia) Co., Ltd.

Bolg2, No.451 Duhui Road,
Minhang District-201108
Shanghai
Tel +86 21 50464748

INDIA

RIELLO POWER INDIA Pvt. Ltd.

318, 3rd Floor Time Tower,
MG Road, Gurgaon-122002
Tel +91-124-4111999

ARABIAN PENINSULA

RIELLO UPS Middle East FZ-LLC

Dubai Science Park
North Tower, 8th Floor, Office 9
Al Barsha South, 500767
Tel. +971 55 7672503



Follow us on Social Networks

